

# BRUSH MASTER™

## Chipper/Shredder with 2-Way Feed Owner's Manual

This manual contains important safety instructions for  
Chipper/Shredder models: CH6, CH8, CH10, CH11  
READ SAFETY WARNINGS AND OPERATING INSTRUCTIONS  
CAREFULLY SAVE THESE INSTRUCTIONS.

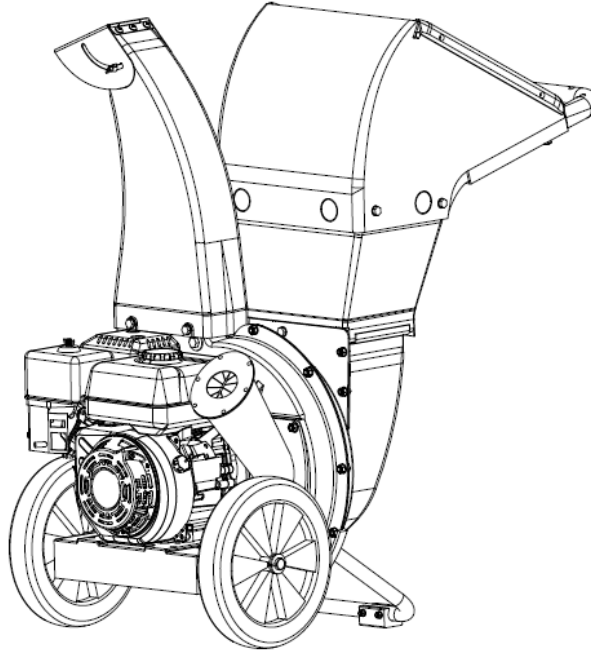

**Do not return this unit to the store!**

For product questions or service,  
**CALL 1-919-550-3221**

or go to [www.beastpowerequipment.com](http://www.beastpowerequipment.com)

When you call the help-line you will need to have the following information:

Date of Purchase: \_\_\_\_\_

Location of Purchase: \_\_\_\_\_

Model #: \_\_\_\_\_

Serial #: \_\_\_\_\_

Serial number is located next to the on off switch on the engine block. See page 3 for more detail.

# **BRUSH MASTER™**

---

Copyright© 2012 by GXi Outdoor Power, LLC. All rights reserved.

No part of this publication can be reproduced or distributed without prior written permission of GXi Outdoor Power, LLC Clayton, NC 27520 USA.

Brush Master™ is a trademark of GXi Outdoor Power, LLC

DEK® is registered trademark of GXi Outdoor Power, LLC

DEK® is exclusively distributed by GXi Outdoor Power, LLC

GXi Outdoor Power, LLC reserves the right to discontinue or change specifications or design at any time without notice and without incurring any obligation what so ever.

The information and specifications included in this publication were in effect at the time of approval for printing.



**This manual contains important safety instructions for Chipper/Shredders**  
**READ SAFETY WARNINGS AND OPERATING INSTRUCTIONS CAREFULLY**  
**SAVE THESE INSTRUCTIONS.**

**This owner's manual is considered a permanent part of the chipper/shredder and should remain with the chipper/shredder if resold.**

# BEAST SERIES

Check out our other great products at  
[www.beastpowerequipment.com](http://www.beastpowerequipment.com)

## TURF BEAST

36-inch & 54-inch Walk Behind Mower



## Z-BEAST

54-inch & 62-inch Zero-Turn Mower



## SNOW BEAST

36-inch & 45-inch Snow Blower



## BRUSH BEAST

36-inch Brush Mower



## BRUSH MASTER

Chipper/Shredder with 2-Way Feed



## THE BEAST

100-inch Tow Behind Mower



## Contents

Warnings.....	1
Product Specifications .....	2
Component Identification .....	3
Missing Parts Order Form.....	4
Identification Component.....	5
Safety Information .....	7
Operating Guidelines .....	8
Assembly .....	9
Important Engine Information .....	10
Operating Instructions .....	12
Maintenance & Storage .....	13
Troubleshooting .....	16
Limited Warranty & Service .....	17

### WARNING

This symbol indicates important safety instructions which, if not followed, could endanger personal safety and/or property. Read and follow all instructions in this manual before attempting to operate this machine. Failure to comply with these instructions may result in personal injury. When you see this symbol—heed its warning.

### WARNING



#### **CARBON MONOXIDE GAS**

Exhaust contains poisonous carbon monoxide, a colorless and odorless gas. Breathing exhaust can cause loss of consciousness and may lead to death.

The Engine Exhaust from this product contains chemicals known to the State of California to cause cancer, birth defects or other reproductive harm.

### WARNING



This machine has a rotating cutting blade capable of amputating hands and feet and throwing objects. Keep hands and feet out of openings while machine is running. Failure to observe these safety instructions could result in serious injury or death.

### WARNING



**WARNING:** Do not operate this machine unless the chute deflector has been installed properly.

### WARNING



Keep bystanders, helpers, pets, and children at least 75 feet from the machine while it is in operation. Stop machine if anyone enters the area.

### WARNING



Wear hearing and eye protection while operating this machine or if you are within 75 feet of this machine. Thrown objects which ricochet can cause serious injury to the eyes.

### WARNING

Never wear loose clothes or long jewelry and keep your long hair under a headgear when operating machine. Never operate this machine in bare feet or sandals. Never use machine on a slope or hard smooth floor.

### WARNING



Gasoline is extremely flammable and the vapors are explosive. Serious personal injury can occur when gasoline is spilled on you or your clothing, which can ignite. In the event of a gasoline spill, wash your skin and change clothes immediately.

**WARNING:** Do not deposit branches larger than 5x3.5 inches in diameter (depending on Model #, see Model Specifications table pg 2) in the limb chute. Do not deposit branches larger than 1/4 inches into the leaf funnel.

DO NOT force the branches into this machine, allow the machine to automatically feed through.

**Training**

1. Read, understand, and follow all instructions on the machine and in the manual before attempting to assemble and operate. Keep this manual in a safe place for future and regular reference and for ordering replacement parts.
2. Be familiar with all controls and their proper operation. Know how to stop the machine and disengage controls quickly.
3. Never allow children under 18 years old to operate this machine. Children 18 years old and over should read and understand the operation instructions and safety rules in this manual and should be trained and supervised by a parent.
4. Never allow adults to operate this machine without proper instruction.
5. Keep bystanders, helpers, pets, and children at least 75 feet from the machine while it is in operation. Stop machine if anyone enters the area.
6. Never run an engine indoors or in a poorly ventilated area. Engine exhaust contains carbon monoxide, an odorless and deadly gas.
7. Do not put hands or feet near rotating parts or in the feeding chambers and discharge opening. Contact with the rotating impeller can amputate fingers, hands, and feet.
8. Never attempt to unclog either the feed intake or discharge opening, or inspect and repair the machine while the engine is running. Shut the engine off and wait until all moving parts have come to a complete stop. Disconnect the spark plug wire and ground it against the engine.

**NOTE:**  
**The operator or user is responsible for accidents or hazards occurring to other people, their property, and themselves.**

**Product Specifications****Chipper/Shredder Model # Specifications**

<b>Model#</b>	<b>CH6</b>	<b>CH8</b>	<b>CH10</b>	<b>CH11</b>
Maximum RPM	3600RPM	3600RPM	3600RPM	3600RPM
Torque	8 Ft Lbs	12 Ft Lbs	17.7 Ft Lbs	17.7 Ft Lbs
Emission Compliance	48 state	48 state	50state	50 state
Fuel Capacity (gal.)	0.87	1.3	1.72	1.72
Oil Capacity (Qts)	0.6	1.1	1.1	1.1
Engine Type	DEK	DEK	DEK	DEK
Displacement (cc)	212cc	270cc	445cc	445cc
Chipper	Yes	Yes	Yes	Yes
Shredder	Yes	Yes	Yes	Yes
Maximum cutting Thickness Diameter (in.)	2.25"	3"	5"×3.5"	5"×3.5"

## Component Identification

### Discharge Chute

Chipped materials are discharged through this opening.

### Leaf Funnel

Use the Leaf funnel to feed leaves and branches no larger than 1/4" only.

### Fuel Tank

Use regular unleaded fuel. Always leave about 1" of air gap at the top of the tank for fuel expansion to prevent seepage or spills.

### Limb Chute

Use the Limb chute to feed longer and/or thicker pieces of yard waste into the impeller for chipping. Depending on the model #, the chipper/shredder can cut up to a 2.25" or 3" or 5"x3.5" diameter piece of wood.

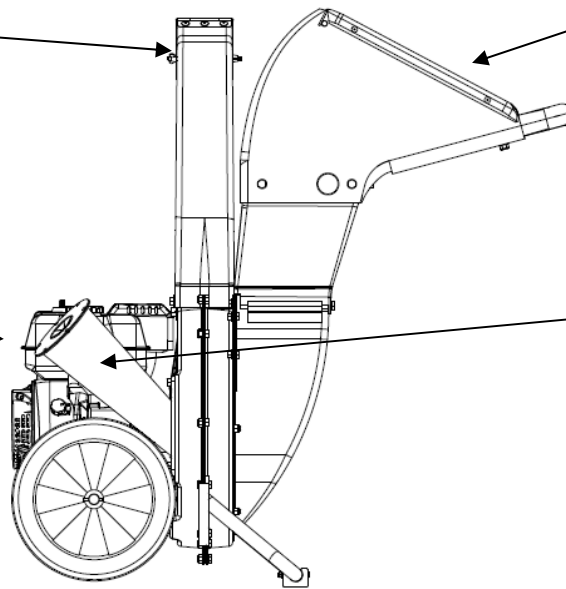

### Choke Lever

Move the choke lever to the CHOKE position to prepare a cold engine for starting.

### Fuel Valve

Use the fuel valve to turn fuel on and off to engine.

### On/Off Switch

Set this to **On** before using recoil starter. Set switch to **Off** to turn off engine.

### Recoil Starter

The starter handle is located on the engine. Pull the starter handle to start engine.

### Serial #:

Stamped on engine block between funnel and engine

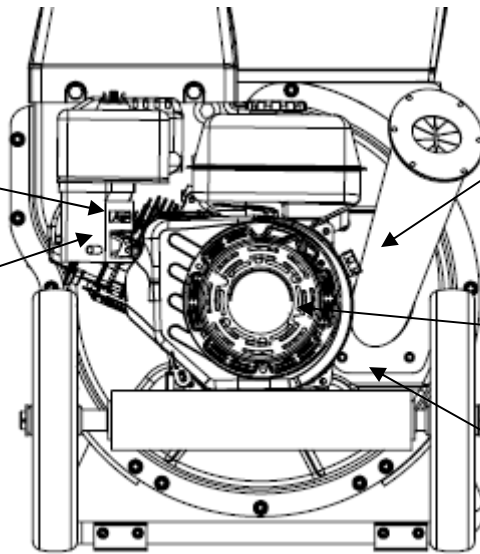

### Hardware Bag (Not shown)

This bag contains the owner's manual, assembly hardware, tools, safety glasses and oil fill funnel

If you are missing any parts, please complete the form on the next page and fax it to us at: 919-550-3277.



# Missing Parts Request Form

Please indicate the part that you are missing:

---

---

\_\_\_\_\_  
Name

\_\_\_\_\_  
Address

Date of purchase \_\_\_\_\_

Model #:

- CH6
- CH8
- CH10
- CH11

\_\_\_\_\_  
Phone

\_\_\_\_\_  
Email

Serial #: \_\_\_\_\_

Comments:

**IMPORTANT: Please include your receipt. Without a receipt, your order will be delayed. You may also email us at:**

**customerservice@gxioutdoorpower.com. If emailing, please scan in your proof of purchase.**

Refer to parts diagram and part list on page 5 and 6 for part numbers. This will expedite the process.



**BEAST Chipper Shredder Spare Parts Diagram**

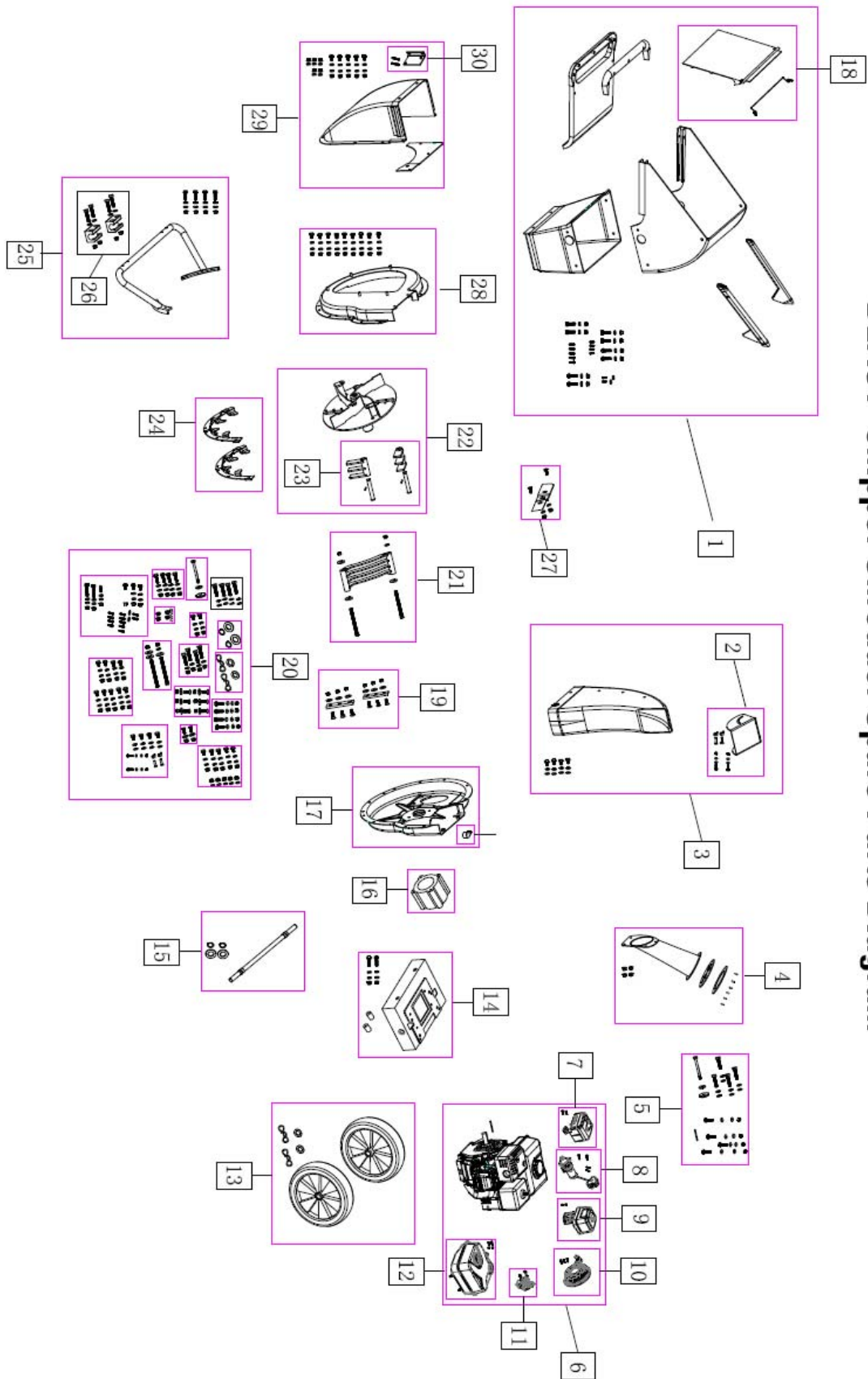

Item #	GXi Part Number	Description	CH6	CH8	CH10	CH11
1	LCSSP13-005	Chipper, plastic leaf funnel assembly kit with hardware and label for BEAST,2013 upgrade	●	●	●	●
2	LCSSP11-002	Chipper, discharge deflector with hardware and label	●	●	●	●
3	LCSSP11-028	Chipper, plastic discharge chute with discharge deflector and hardware, label for BEAST	●	●	●	●
4	LCSSP11-022	Chipper, BEAST grey, limb chute, 2.25" capacity, with hardware and label	●			
	LCSSP11-023	Chipper, BEAST grey, limb chute, 3" capacity, with hardware and label		●		
	LCSSP16-065	Chipper, BEAST grey, limb chute, 3.5" *5" capacity, with hardware and label			●	●
5	LCSSP11-004	Chipper, hardware kit, engine fasteners with engine shaft key	●	●	●	●
6	E12013	Engine assembly, 212cc, black paint, labels for BEAST included..	●			
	E10113	Engine assembly, 270cc, black paint, labels with BEAST included.		●		
	E14417	engine -445cc no attach electric starter, EPA			●	
	E14517	445cc, Engine assembly with electric starter,, black paint, labels for BEAST included..				●
7	LCSSP17-075	Muffler assembly 445cc,for Chipper models:CH10,CH11,includes the muffler, muffler cover, a bracket, bolts and gaskets.			●	●
	LCSSP12-047	Air filter assembly 212cc,for Chipper models:CH2,CH6,includes the filter cover, filter media, housing and bolts.	●			
	LCSSP12-048	Air filter assembly 270cc,for Chipper models:CH7,CH8,includes the filter cover, filter media, housing and bolts.		●		
8	LCSSP17-076	Electric starter, engine ,use for 445cc...				●
9	LCSSP17-077	Air filter assembly 445cc,for Chipper models:CH10,CH11,includes the filter cover, filter media, housing and bolts.			●	●
	LCSSP12-049	Air filter assembly 212cc,for Chipper models:CH2,CH6,includes the filter cover, filter media, housing and bolts.	●			
	LCSSP12-050	Air filter assembly 270cc,for Chipper models:CH7,CH8,includes the filter cover, filter media, housing and bolts.		●		
10	LCSSP17-078	Recoil assembly 445cc,BEAST,for Chipper models:CH10 CH11 includes recoil housing, reel, recoil rope, pull start grip and label. Simply install this recoil assembly with three bolts.			●	●
	LCSSP12-046	Recoil assembly 270cc,BEAST,for Chipper models:CH8 includes recoil housing, reel, recoil rope, pull start grip and label. Simply install this recoil assembly with three bolts.	●			
	LCSSP13-044	Recoil assembly 212cc,BEAST,for Chipper models:CH6 includes recoil housing, reel, recoil rope, pull start grip and label. Simply install this recoil assembly with three bolts.		●		
11	LCSSP17-079	Carburetor assembly 445cc,for Chipper models:CH10,CH11, includes the carburetor, the choke shaft, the heat shield and the gaskets. Simply install the carburetor assembly onto the engine head with two bolts.			●	●
	LCSSP12-053	Carburetor assembly 212cc,for Chipper models:CH2,CH6,includes the carburetor, the choke shaft, the heat shield and the gaskets. Simply install the carburetor assembly onto the engine head with two bolts.	●			
	LCSSP12-054	Carburetor assembly 270cc,for Chipper models:CH7,CH8, includes the carburetor, the choke shaft, the heat shield and the gaskets. Simply install the carburetor assembly onto the engine head with two bolts.		●		

12	LCSSP17-080	Fuel tank assembly 445cc, BEAST, for Chipper models: CH10 CH11, includes the tank, Roll over valve, fuel cap, label and is ready to be connected to the carburetor.			●	●
	LCSSP12-040	Fuel tank assembly 212cc, BEAST, for Chipper models: CH6, includes the tank, Roll over valve, fuel cap, label and is ready to be connected to the carburetor.	●			
	LCSSP12-042	Fuel tank assembly 270cc, BEAST, for Chipper models: CH8, includes the tank, Roll over valve, fuel cap, label and is ready to be connected to the carburetor.		●		
13	LCSSP16-066	Chipper, wheels, solid rubber, plastic rim, double two with retaining hardware to axle, use for CH10 and CH11...			●	●
	LCSSP13-020	Chipper, wheels, solid rubber, plastic rim, with retaining hardware to axle, 2013 upgrade	●	●		
14	LCSSP16-067	Chipper, 457cc engine, chassis with BEAST label and hardware to mount to flail housing			●	●
	LCSSP12-029	Chipper, 212cc engine, chassis with BEAST label and hardware to mount to flail housing	●			
	LCSSP12-030	Chipper, 270cc engine, chassis with BEAST label and hardware to mount to flail housing		●		
15	LCSSP11-019	Chipper, axle, with retaining hardware with chassis	●			
	LCSSP16-068	Chipper, axle, with retaining hardware with chassis, use for CH10 and CH11...			●	●
16	LCS16-173	Adapter, engine to flail housing, CH10, nylon, chipper			●	
	LCS16-195	Adapter, engine to flail housing, CH11, nylon, chipper				●
	LCS13-039	Adapter, engine to flail housing, 212cc, nylon, chipper	●			
	LCS13-040	Adapter, engine to flail housing, 270cc, nylon, chipper		●		
17	LCS11-043	Flail housing, engine side, 212cc, steel, grey, chipper..	●			
	LCS11-089	Chipper, flail housing, engine side, 270cc, BEAST grey		●		
	LCSSP16-069	Flail housing assembly, engine side, 457cc, steel, chipper..			●	●
18	LCSSP12-034	Funnel, entry shield, plastic, white, chipper with BEAST label, with spring	●	●	●	●
19	LCSSP11-018	Chipper, blade set of two with hardware	●	●	●	●
20	LCSSP11-016	Chipper, hardware kit, complete assembly minus engine hardware	●	●	●	●
21	LCSSP11-009	Chipper, discharge screen, cast steel, black, with hardware	●	●	●	●
22	LCSSP16-070	Chipper, rotor assembly with hammers, blades not included, longer shaft...				●
	LCSSP11-012	Chipper, rotor assembly with hammers, blades not included	●	●	●	
23	LCSSP11-008	Chipper, hammers, set of two with pins and retainers	●	●	●	●
24	LCSSP11-015	Chipper, stationary shredder teeth, set of 2, steel, black	●	●	●	●
25	LCSSP11-027	Chipper, foot assembly, 270cc, black with rubber feet	●	●		
	LCSSP16-071	Chipper, foot assembly, 457cc, black with rubber feet			●	●
26	LCSSP11-017	Chipper, rubber feet with hardware	●	●	●	●
27	LCSSP11-010	Chipper, leaf chute blade with hardware	●	●	●	●
28	LCSSP11-025	Chipper, flail housing, leaf chute side, BEAST grey	●	●	●	●
29	LCSSP12-032	CH8 chipper, leaf chute base, steel, BEAST grey with back plate and hardware with label		●		
	LCSSP13-026	CH6 Chipper, leaf chute base, steel, BEAST grey with back plate and hardware, 2013	●			
	LCSSP16-072	Chipper, leaf chute base, steel, BEAST grey with back plate and hardware with label, use for CH10...			●	
	LCSSP16-073	Chipper, leaf chute base, steel, BEAST grey with back plate and hardware with label, use for CH11...				●
30	LCSSP16-074	Support plate assembly, electrical starting, use for CH11...				●

**Your Responsibility**

**Restrict the use of this chipper/shredder to persons who read, understand and follow the warnings and instructions in this manual and on the machine.**

Note: Not all safety labels shown may apply to your chipper/shredder.

**Preparation**

1. Thoroughly inspect the area where the chipper/shredder is to be used. Remove all rocks, bottles, cans, or other foreign objects which could be picked up or thrown and cause personal injury or damage to the machine.
2. Avoid discharging chipped material out of the discharge chute against a wall or on asphalt, concrete, or other hard surfaces as material being ejected could ricochet, causing injury to you or bystanders.
3. Always wear safety glasses or safety goggles to protect eyes during operation or while performing an adjustment or repair.
4. Wear sturdy, rough-soled work shoes and closefitting pants and shirts. Loose fitting clothing or jewelry can be caught in movable parts. Wear leather work gloves when feeding material in the chipper chute.
5. Before starting the engine, check bolts and screws for proper tightness to be sure the machine is in safe working condition. Also, visually inspect the chipper shredder at frequent intervals for any damage.
6. Maintain or replace safety and instructions labels, as necessary.
7. To avoid personal injury or property damage use extreme care in handling gasoline.
  - a. Use only an approved gasoline container.
  - b. Extinguish all cigarettes, cigars, pipes, and other sources of ignition.
  - c. Never fuel machine indoors.
  - d. Never remove gas cap or add fuel while the engine is hot or running.
  - e. Allow engine to cool at least two minutes before refueling.
  - f. Never over fill fuel tank. Always leave about 1 inch open below bottom of filler neck to provide space for fuel expansion.
  - g. Tighten gasoline cap securely.
  - h. If gasoline is spilled, wipe it off the engine and equipment. Move machine to another area and wait 5 minutes before starting the engine.
8. Never attempt to make any adjustments while the engine (motor) is running (except where specifically recommended by the manufacturer).
  - i. Never store machine or fuel container inside near an open flame, spark, or pilot light (e.g., furnace, water heater, space heater, clothes dryer, etc.).
  - j. To reduce the fire hazard, keep machine free of grass, leaves, or other debris build-up. Clean up oil or fuel spills and remove any fuel soaked debris.
  - k. Allow machine to cool at least 5 minutes before storing.

**Safety Label Locations**

These labels warn you of potential hazards that can cause serious injury. Read them carefully. If a label comes off or becomes hard to read, contact your GXi Outdoor Power dealer for a replacement.

**Safety Information**

GXi Outdoor Power products are designed to give safe and dependable service if operated according to instructions. Read and understand this owner's manual before operating your power equipment.

**Operator Responsibility**

Never allow children under 18 years old to operate this machine. Children 18 years old and over should read and understand the operation instructions and safety rules in this manual and should be trained and supervised by a parent.

### READ THESE OPERATING GUIDELINES BEFORE YOU PROCEED ANY FURTHER

1. Do not put hands and feet near rotating parts or in the feeding chambers and discharge opening. Contact with the rotating impeller can amputate fingers, hands, and feet.
2. Before starting the machine, make sure the chipper chute, feed intake, and cutting chamber are empty and free of all debris.
3. Thoroughly inspect all material to be shredded and remove any metal, rocks, bottles, cans, or other foreign objects which could cause personal injury or damage to the machine.
4. If it becomes necessary to push material through the shredder hopper, use a small diameter stick. Do not use your hands or feet.
5. If the impeller strikes a foreign object or if your machine should start making an unusual noise or vibration, immediately shut the engine off. Allow the impeller to come to a complete stop. Disconnect the spark plug wire, ground it against the engine and perform the following steps:
  - a. Inspect for damage.
  - b. Repair or replace any damaged parts.
  - c. Check for any loose parts and tighten to assure continued safe operation.
6. Do not allow an accumulation of processed material to build up in the discharge area. This can prevent proper discharge and result in kickback of material through the feed opening.
7. Do not attempt to shred or chip material larger than specified on the machine or in this manual. Personal injury or machine damage could result.

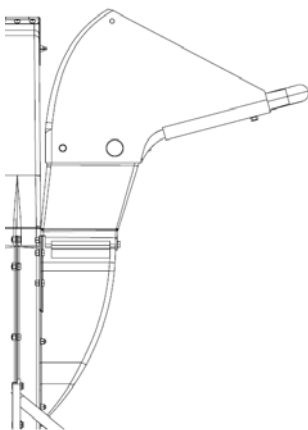

The funnel on the chipper/shredder is for leaves only. **Do not use the funnel for vines, wet vegetation, or long branches such as Weeping Willows as they may clog the cutting chamber.**

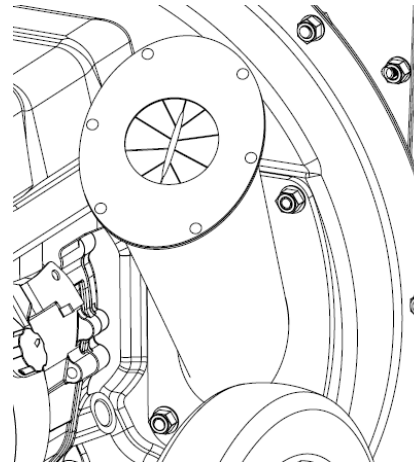

The side chute is for longer and/or thicker pieces of yard waste. Depending on your model, you may chip to your models capacity (page 2).

8. Never attempt to unclog either the feed intake or discharge opening while the engine is running. Shut the engine off, wait until all moving parts have stopped, disconnect the spark plug wire and ground it against the engine before clearing debris.
9. Never operate without the leaf funnel, limb chute, or discharge chute properly attached to the machine. Stop the engine when leaving the operating position.
10. Keep all guards, deflectors and safety devices in place and operating properly.
11. Keep your face and body back and to the side of the chipper chute while feeding material into the machine to avoid accidental kickback injuries.
12. Never operate this machine without good visibility or light.
13. Do not operate on a non-level surface.
14. Do not operate in a confined space.
15. Do not operate this machine while under the influence of alcohol or drugs.
16. Muffler and engine become hot and can cause a burn. Do not touch.
17. Never pick up or carry machine while the engine is running.
18. Do not leave this machine running while unattended.
19. Keep children, bystanders, and pets 75 feet away.
20. Use only manufacturer approved accessories/ attachments.



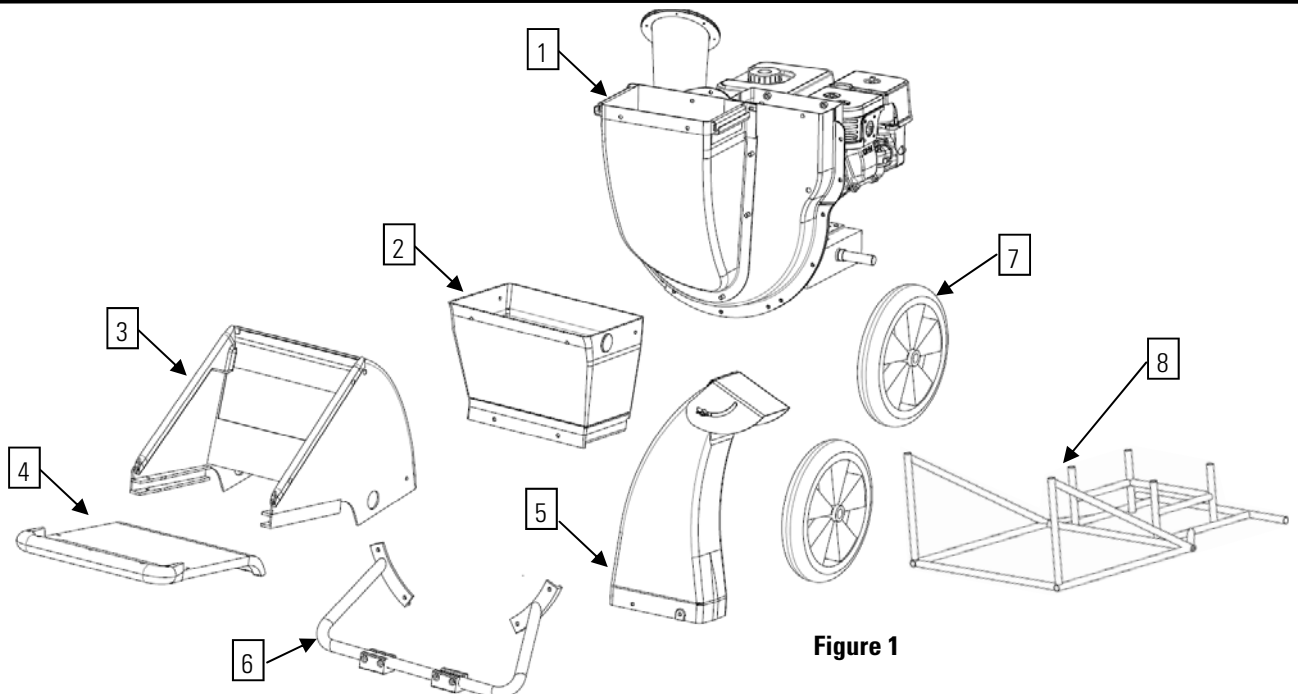

**Figure 1**

**IMPORTANT:** This unit is shipped without gasoline or oil in the engine. Be certain to fill the engine with gasoline and oil as instructed before operating your machine.

**Required tools:** Two 13mm wrenches

**NOTE:** Both wrenches are supplied in the hardware bag.

**Approximate assembly time:** 15 minutes

**1. Remove the chipper from its carton**

Remove plastic banding and cut the tape on the top of the box.

**2. Remove the shipping frame (item 8) from item 1 (CH6 and CH8 only)**

The steel shipping frame (item 8) is banded to the base of the chipper at the engine mounting location. Cut these bands with scissors or a knife to remove the chipper from the shipping frame. The shipping frame can be discarded.

**3. Verify all chipper components are present (Figure 1)**

Item 1: Engine/chipper body/wheels subassembly (CH6 and CH8 only)

Item 2: Lower leaf funnel section

Item 3: Upper leaf funnel section with entry shield

Item 4: Handle section and leaf funnel base

Item 5: Discharge chute with deflector

Item 6: Support foot with rubber foot (CH10 and CH11 only)

Item 7: Wheels (CH10 and CH11 only)

Item 8: Shipping frame(CH6 and CH8 only)

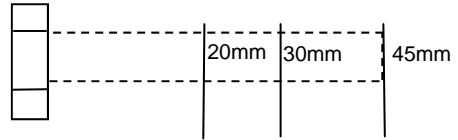

**Figure 2**

#### 4. Verify all parts are in the hardware bag (Figure 2)

- Goggles (eye protection)
- Wrenches for assembly and blade maintenance
- Allen wrench for blade maintenance
- Oil funnel with flexible neck
- Spark plug wrench
- Owner's Manual
- Hardware: eleven 20mm long bolts, two 30mm long bolts, two 45mm long bolts, 26 flat washers, 4 locking washers and 11 nylon locking nuts

Bolt Identification:  
Place top of bolt head here  
Actual Size



#### 5. Disconnect The Spark Plug Wire

Before setting up your chipper shredder, disconnect the spark plug wire from the spark plug and ground against the engine to prevent inadvertent starting of the machine. This step should be taken as a precaution whenever you are working on this machine.

#### 6. Attaching the chipper wheels (Figure 7)

First remove the spring pin and washer of right and left wheel shift, then assemble the two wheels on right and left wheel shift, and fasten at outside of the wheel with the removed spring pin and washer.

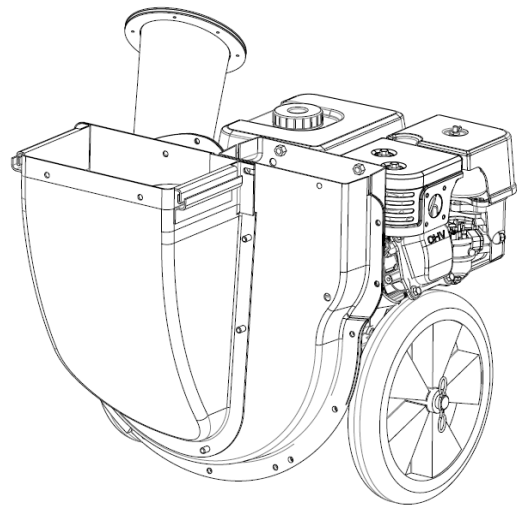

Figure 7

#### 7. Attaching the lower leaf funnel section. (Figure 6)

Assemble foot support on the position where no fasten bolt of the front housing, there's reserved standard parts on it, left side fasten with two M8\*20 bolt, 4 washer, 2 lock nut, right side fasten with 2 M8\*25 bolt, 4 washer, 2 lock nut.

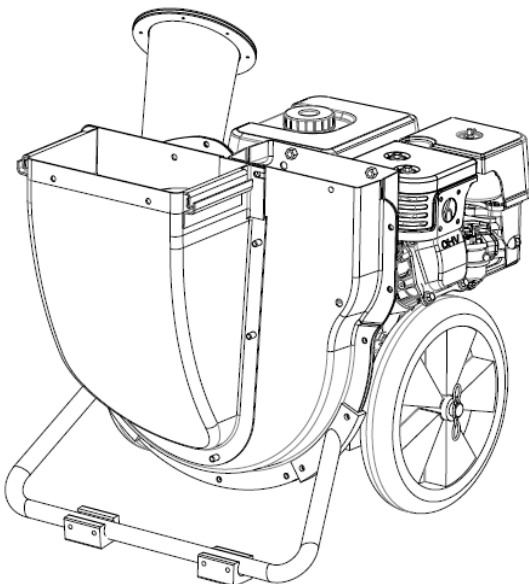

Figure 6

### 8. Attaching the chipper discharge chute (Figure 3)

Place discharge chute over rectangular opening on the chipper body. The plastic discharge chute fits on the outside of the steel chipper body. The steel liner inside the plastic discharge chute also fits outside of the steel chipper body. Attach with four 20mm long bolts with lock washers and flat washers. No nuts required for these connections.

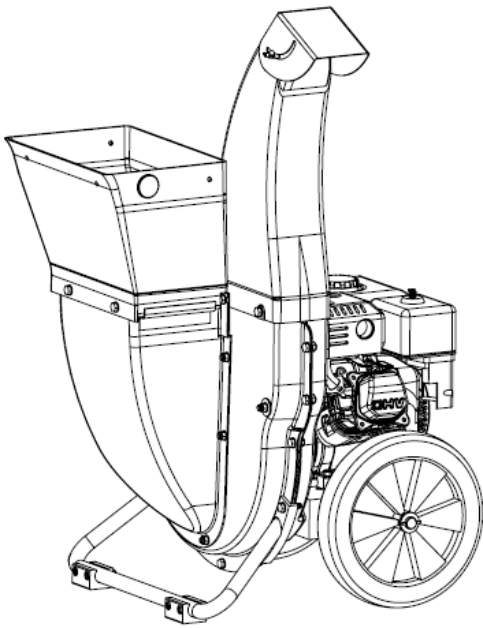

Figure 4

### 10. Attach the handle section and leaf funnel base to the upper leaf funnel with entry shield.

First attach the upper funnel section to the lower funnel section and align using the large round protrusions and holes. Insert two bolts (one in each side) in the holes closest to the engine.

Second spread the open end of the upper funnel section and insert the handle section in the slot on both sides.

Third fasten the components together with the remaining 8 fasteners. Each bolt should have two flat washers and a nylon nut.

### 11. Re-connect the spark plug wire

### 12. Add oil and fuel.

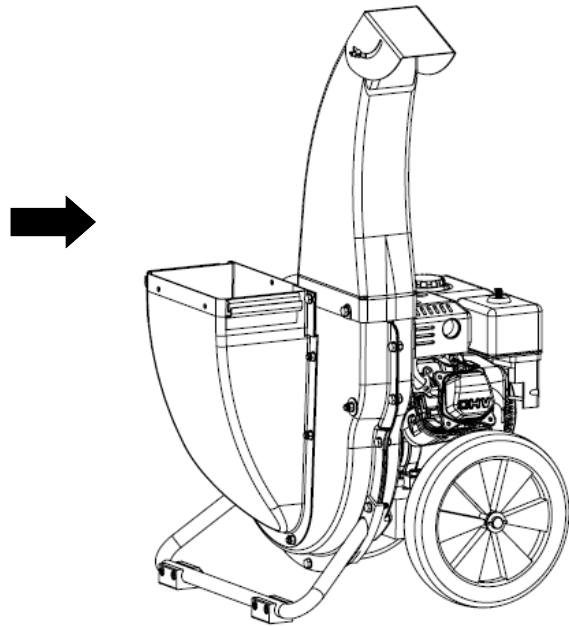

Figure 3

### 9. Attaching the lower leaf funnel section. (Figure 4)

The plastic part has a hook shape on the bottom side. The hook shape slides into the steel track on the chipper body. When the two parts have been connected, fasten with three 20mm long bolts, a flat washer on each side, and nylon nuts.



45mm bolts fasten here

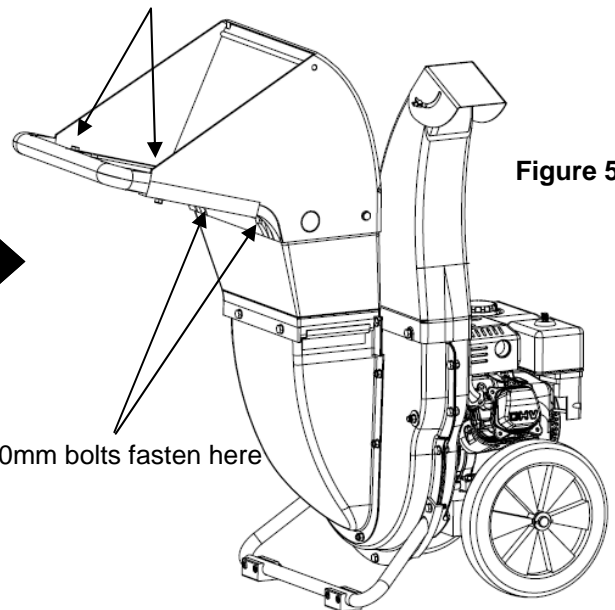

Figure 5

30mm bolts fasten here



**NOTE:** The chipper/shredder operates most efficiently at the factory set engine speed of 3600 RPM. The speed is controlled by the governor, and the throttle setting should not be adjusted. Do not attempt to adjust the speed of the engine.

### Emission Control System Information

#### The U.S. and California Clean Air Acts

EPA and California regulations require all manufacturers to furnish written instructions describing the operation and maintenance of emission control systems. The following instructions and procedures must be followed in order to keep the emissions from your DEK engine within the emission standards.

The emission control systems on your DEK engine were designed, built, and certified to conform with EPA and California emission regulations.

Maintenance, replacement, or repair of the emission control devices and systems may be performed by any engine repair provider, using parts that are “certified” to EPA standards. We recommend the use of genuine DEK parts whenever you have maintenance done. These original-design replacement parts are manufactured to the same standards as the original parts, so you can be confident of their performance.

The use of aftermarket replacement parts, not of the original design and quality, may impair the effectiveness of your emission control system. A manufacturer of an aftermarket part assumes the responsibility that the part will not adversely affect emission control performance and must certify that use of the part will comply with emission regulations.

In the State of California a spark arrestor is required by law. Other states may have similar laws. Federal laws apply on all federal lands. If you equip the muffler with a spark arrestor, it must be maintained in effective working order.



### Carbon Monoxide Gas

Exhaust contains poisonous carbon monoxide, a colorless and odorless gas. Breathing exhaust can cause loss of consciousness and may lead to death. To keep exhaust gas from accumulating, DO NOT use this product in a garage, basement, crawlspace, enclosed shed, or any other area without adequate ventilation. DO NOT use this equipment near ventilation ducts or open windows that may allow exhaust gasses to enter your home or business. ONLY operate this product outdoors.

The engine exhaust from this product and other components contain chemicals known to the State of California to cause cancer, birth defects or other reproductive harm.



### Fire and Burn Hazards

The exhaust system gets hot enough to ignite some materials.

- Keep the power equipment at least 3 feet (1 meter) away from buildings and other equipment during operation.
- Do not enclose this product in any structure.
- Do not smoke when refueling.
- Keep flammable materials away.
- The muffler becomes very hot during operation and remains hot for a while after stopping the engine. Be careful not to touch the muffler while it is hot.
- Let the engine cool before storing.
- Refuel in a well ventilated area with the engine stopped.
- Fuel vapors are extremely flammable and may ignite after the engine has started. Make sure that any spilled fuel has been wiped up before starting the engine.



This machine was built to be operated according to the rules for safe operation in this manual. As with any type of power equipment, carelessness or error on the part of the operator can result in serious injury.



Always wear hearing and eye protection while operating this machine or if you are within 75 feet of this machine.

**IMPORTANT:** This unit is shipped without gasoline or oil in the engine. Be certain to fill the engine with gasoline and oil as instructed before operating your machine.



### Add Gasoline and Oil

**Step 1:** Add gasoline

**Step 2:** Add 10W-30 oil until the oil is about to overflow from the oil fill spout. (see page 2 for capacity) A low oil sensor will prevent the engine from running unless the oil is **COMPLETELY FULL**. Ensure **both** oil fill plugs are secure after filling.

**Never fill fuel tank indoors with engine running or until the engine has been allowed to cool for at least two minutes after running.**

### Starting the Engine

**Step 3:** Attach spark plug wire to spark plug. Make certain the plug wire on the end of the spark plug is fastened securely over the metal tip on the spark plug.

**Step 4:** Move choke lever on engine to **CHOKE** position. (A warm engine may not require choking).

**Step 5:** Turn the fuel valve to the **ON** position.

**Step 6:** Grasp starter handle and pull rope out slowly until engine reaches start of compression cycle (rope will pull slightly harder at this point). Pull rope with a rapid, continuous, full arm stroke. Keep a firm grip on starter handle. Let the rope rewind slowly. Repeat the previous steps until engine fires.

**Rapid retraction of the recoil starter cord can pull the starter cord back faster than you can let go. When starting the engine, pull the cord slowly until resistance is felt then pull rapidly to avoid kickback.**

**NOTE:** A noise will be heard when finding the start of the compression cycle. This noise is caused by the flails and fingers, which are part of the shredding mechanism, and it should be expected until the impeller reaches full speed.

**Step 7:** When engine starts, move choke control gradually to the **RUN** position.

### Using the Chipper Shredder

Yard waste such as leaves and pine needles can be raked up and placed in the chipper funnel for shredding. **DO NOT PUT BRANCHES INTO THE LEAF FUNNEL. BRANCHES SHOULD BE FED INTO THE LIMB CHUTE.**

**Do not attempt to use the side chute while using the funnel at the same time.**

When using the limb chute to chip branches, it is important to let the chipper feed the branches through automatically. **DO NOT** attempt to force the branches through. If the branches do not automatically feed through, gently push the branch and then allow the chipper to automatically feed the branch through.

Once material is shredded by the hammers on the impeller assembly, it is discharged through the open discharge chute.

Do not attempt to shred or chip any material other than normal yard vegetation found (i.e., branches, leaves, twigs, etc.) Avoid fibrous, wet vegetation such as tomato vines until they are thoroughly dried. Twigs and small branches can be fed into the limb chute. (See model specifications for maximum cutting thickness.)

**IMPORTANT:** The hammer screen is located inside the housing in the discharge area. If the screen becomes clogged, remove and clean as instructed. For best performance, it is also important to keep the chipper blades sharp.

If the discharge area becomes clogged:

- Stop the engine. Disconnect spark plug wire from spark plug and ground against the engine.
- Remove leaf funnel
- Reach in and clear the debris causing the blockage. Reinstall the funnel and the clean out access hatch.
- Connect the spark plug wire and restart.

**NOTE:** If the blockage is severe, the hammer screen within the discharge chute can be removed as well, providing greater access. To accomplish this, remove the discharge chute and the flail screen out of the discharge chute.

### Maintenance Schedule

Item	Before each use	20 hrs or every 3 months	50 hrs or every 3 months	100 hrs or every 6 months	300 hrs or every 1 year
Check for loose fasteners (check)	X				
Engine Oil (Check)	X				
Engine Oil (Change)		X			
Air Cleaner (Check)	X				
Air Cleaner Wash			X		
Fuel filter Cup (Clean)				X	
Spark Plug (Clean)				X	
Spark Plug (Change)					X
Check Chipper Blade	X				
Fuel Tank and Filter (Clean)		X			



**Always stop engine, disconnect spark plug, and ground against engine before cleaning, lubricating or doing any kind of maintenance on your machine.**

### Maintenance and Storage

- Never tamper with safety devices. Check their proper operation regularly.
- Check bolts and screws for proper tightness at frequent intervals to keep the machine in safe working condition. Also, visually inspect machine for any damage and repair, if needed.
- Before cleaning, repairing, or inspecting, stop the engine and make certain the impeller and all moving parts have stopped. Disconnect the spark plug wire and ground it against the engine to prevent unintended starting.
- Do not change the engine governor settings or overspeed the engine. The governor controls the maximum safe operating speed of the engine.
- Maintain or replace safety and instruction labels, as necessary.

- Follow this manual for safe loading, unloading, transporting, and storage of this machine.
- Never store the machine or fuel container inside where there is an open flame, spark or pilot light such as a water heater, furnace, clothes dryer, etc.
- Always refer to the operator's manual for proper instructions on off-season storage.
- If the fuel tank has to be drained, do this outdoors.
- Observe proper disposal laws and regulations for gas, oil, etc. to protect the environment.

### If the Chipper Becomes Clogged:

If the discharge area becomes clogged:

- Stop the engine. Disconnect spark plug wire from spark plug and ground against the engine.
- Remove leaf funnel
- Reach in and clear the debris causing the blockage. Reinstall the funnel and the clean out access hatch.
- Connect the spark plug wire and restart.

**NOTE:** If the blockage is severe, the hammer screen within the discharge chute can be removed as well, providing greater access. To accomplish this, remove the discharge chute and the flail screen out of the discharge chute.

**WARNING**

Always stop engine, disconnect spark plug, and ground against engine before cleaning, lubricating or doing any kind of maintenance on your machine.

### Removing and Sharpening the Limb Chute Blades

The chipper was shipped with **two blades** attached spare blades are sold in sets from GXi (Part Number LCSSP11-018)

1. Disconnect the spark plug wire and ground against the engine.
2. Remove limb chute by removing the four nylon nuts that attach the limb chute to the flail housing using the 13mm wrench provided in the hardware bag (do not use the thin stamped steel wrench)
3. Remove the lower section and upper section of the funnel as a subassembly. This is done by removing three bolts with the 13mm wrenches provided in the hardware bag.
4. Remove the blade using an Allen wrench on the outside of the blade through the limb chute opening, and a 13mm wrench through the leaf funnel opening to remove the three fasteners from each blade.  
After removing one blade, turn the rotor by hand until the second blade is visible through the limb chute opening.
5. Replace or sharpen the blade.
6. When sharpening the blade, protect hands by using gloves and follow the original angle of grind. Torque to 21-25 Ft lbs.

**NOTE:** Make certain the blade is reassembled with the sharp edge facing down. (The long edge of the blade will be toward the limb chute.) Always sharpen or replace blades in sets to ensure smooth operation.

**WARNING:** All guards, chutes, and fasteners must be assembled in their proper locations before attempting to start the chipper shredder.

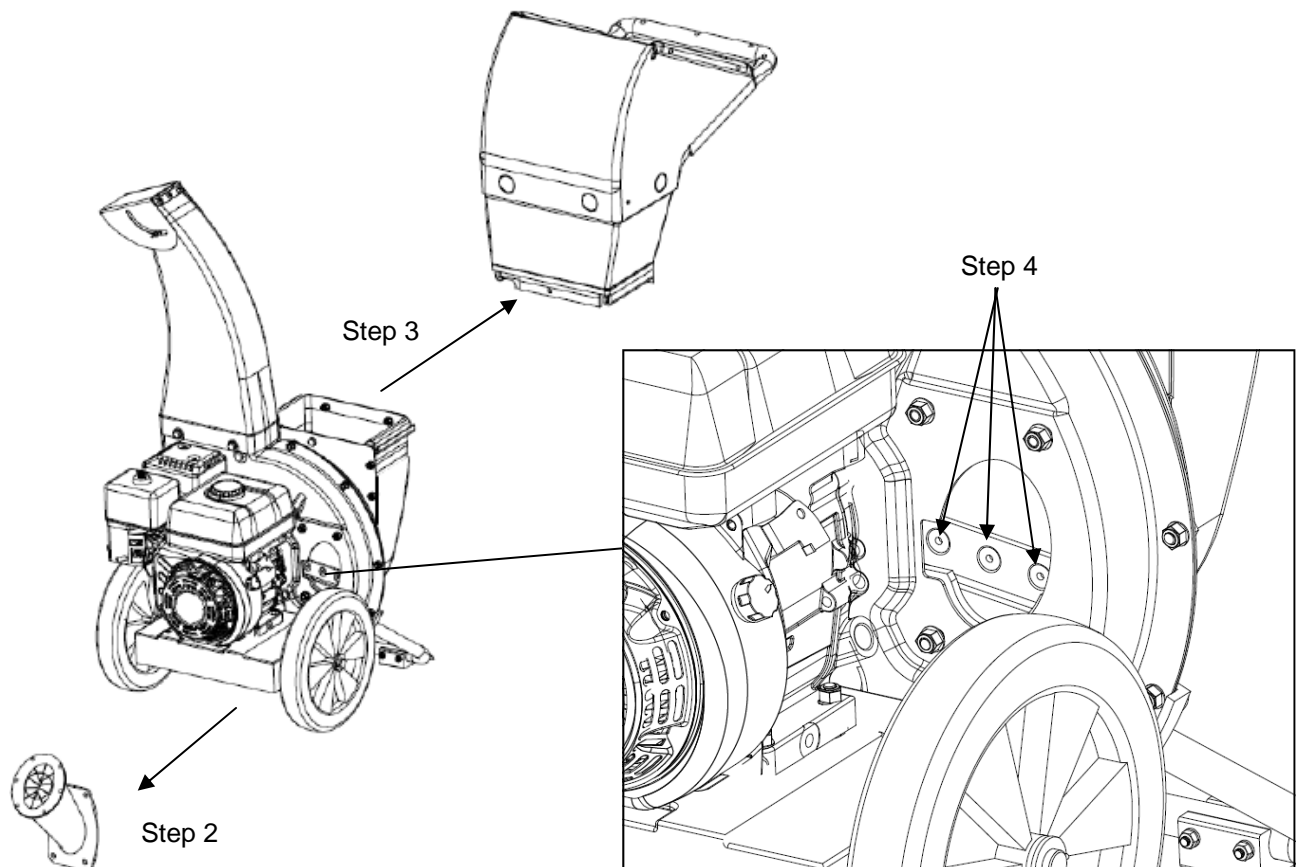

**WARNING**

Always stop engine, disconnect spark plug, and ground against engine before cleaning, lubricating or doing any kind of maintenance on your machine.

### Removing and Sharpening the Leaf Funnel Blade

1. Disconnect the spark plug wire and ground against the engine.
2. Remove the lower section and upper section of the funnel as a subassembly. This is done by removing three bolts with the 13mm wrenches provided in the hardware bag.
3. Remove the two blade bolts using an Allen wrench provided in the hardware bag. It may be necessary to use a block of wood to prevent the rotor from turning while loosening and retightening the blade bolts. Make certain the block of wood is removed before reassembly of the funnel.
4. Replace or sharpen the blade.
  - When sharpening the blade, protect hands by using gloves and following the original angle of grind. Torque to 21-25 Ft lbs.
  - When reinstalling the blade note the orientation. The top of the blade will have the cutting edge to the left and the bottom edge to the right.

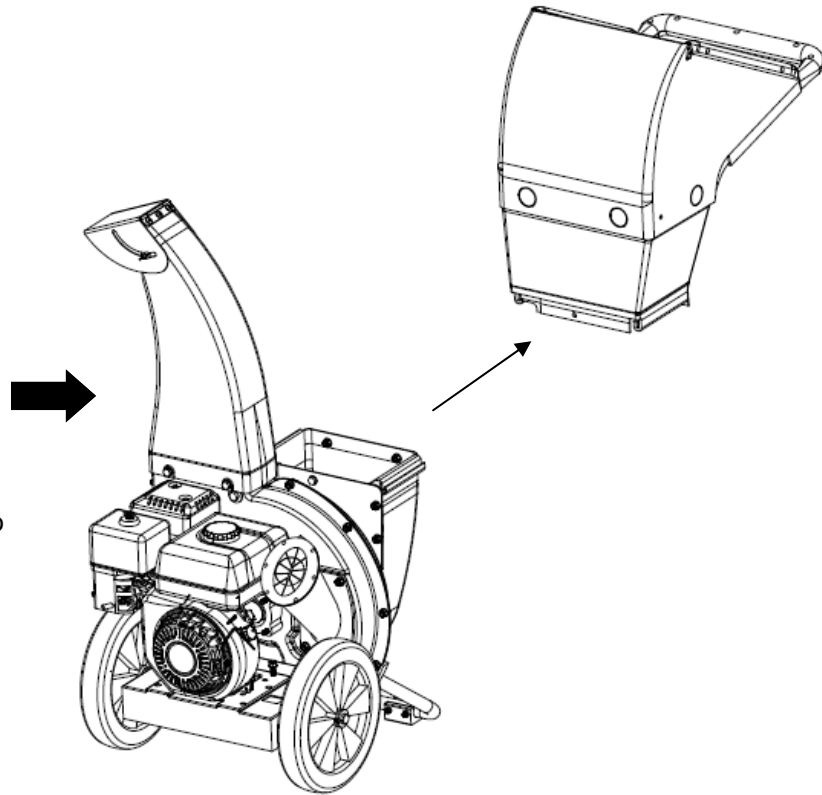

### Removing and replacing the flail hammers

- Disconnect the spark plug wire and ground against the engine.
  - Remove the leaf funnel and limb chute.
  - Remove the retainer clip for the flail hammer pin. Use a piece of pipe or wood to block the flails, preventing them from inadvertently turning.
  - Remove the flail hammer pin through the limb chute opening.
  - Replace the flail hammer, flail hammer pin and retaining clip.

### Cleaning the Chipper/Shredder

- Make sure engine is off.
- Wipe off machine with an oiled rag to prevent rust.
- If the fuel tank has to be drained, do so outdoors.
- Observe proper disposal laws and regulations for gas, oil, etc., to protect the environment.

### To Change the Oil

- Move the unit to flat ground.
- Remove spark plug and ground it to the engine block.
- Place an oil collection pan under the unit.
- Remove one of the 10mm oil drain plugs. (located on the bottom center of the engine behind the wheel)
- Allow oil to drain completely.
- Reinstall the oil drain plug
- Add new 10W-30 oil. See page 2 for oil capacity.
- Reinstall the spark plug.
- Please dispose of used motor responsibly and according to local regulations.

### Storing the Chipper/Shredder

- Clean the equipment thoroughly.
- Wipe equipment with an oiled rag to prevent rust.
- Refer to engine manual for correct engine storage instructions.
- Store unit in a clean, dry area. Do not store next to corrosive materials such as fertilizer.
- Never store the machine or fuel container inside where there is an open flame, spark or pilot light such as a water heater, furnace, clothes dryer, etc.

## Optimizing Chipper Performance – Keep the Blade Sharp!

**During operation, if you notice any of the following symptoms, your chipper blade probably needs to be sharpened:**

1. Chipper does not auto-feed
2. Chipper produces “chunks” or “sawdust” instead of “chips”
3. Chipper engine bogs down or labors
4. Smoke issues from the drive belt
5. Chipper jams or stops altogether

**For optimal chipping**, you will need to sharpen and/or replace your chipper’s blade frequently. Similar to the teeth of a chainsaw, your chipper blade requires frequent sharpening. We recommend that you check the blade for sharpness before each use and after every 2-3 hours of operation.

Some models contain a spare blade in the hardware bag. If you require additional blades, they can be purchased from GXi customer service at 919-550-3221.

As a rough guide, your chipper blade will require sharpening after 4-8 hours of normal use when chipping harder woods such as maple or oak. When chipping softer woods such as poplar and pine, the blade can last 10-20 hours before sharpening is required. If you hit a foreign object such as a stone or nail or if you are processing limbs that have small amounts of sand or soil on them, you will need to sharpen the blade much more frequently.

**Operating the chipper with a sharp blade will extend the life of :**

1. **The blade** because if a chipper blade becomes too dull, much of the blade itself will have to be removed during the sharpening process. Frequent sharpening maintenance as needed is best. Occasional, intensive sharpening will greatly diminish the life of the chipper blade.
2. **The belt** because as the blade becomes dull, the forces on the belt increase and belt wear is accelerated.
3. **The chipper structure** because if wood is forced into a chipper with a dull blade, the force can bend the feed chute, bend the blade carousel and/or shear the bearing bolts.

**To remove and/or replace the blade, please follow the instructions in the owner’s manual.**

Since the blade is hardened steel, it should be sharpened on a wet wheel, or by hand on a stone. (Avoid sharpening the blade using a grinder the way you would a lawn mower blade. If you do, the localized heat will cause the steel to lose its tempered edge and the blade will dull more quickly in use). While many customers are comfortable sharpening their own blade, most local service centers will sharpen your blade for a small fee. If you need assistance finding a service center or with blade sharpening, please call the GXi customer service team at 919-550-3221.

<b>Problem</b>	<b>Cause</b>	<b>Remedy</b>
Engine fails to start	<ol style="list-style-type: none"> <li>1. Spark plug wire disconnected.</li> <li>2. Fuel tank empty or stale fuel.</li> <li>3. Throttle control lever not in correct starting position. (If equipped)</li> <li>4. Choke not in CHOKE position. (If equipped)</li> <li>5. Engine not primed.</li> <li>6. Blocked fuel line.</li> <li>7. Faulty spark plug.</li> <li>8. Low oil</li> </ol>	<ol style="list-style-type: none"> <li>1. Connect wire to spark plug.</li> <li>2. Fill tank with clean, fresh gasoline.</li> <li>3. Move throttle lever to FAST position.</li> <li>4. Move choke to CHOKE position.</li> <li>5. Prime engine.</li> <li>6. Clean fuel line.</li> <li>7. Clean, adjust gap, or replace.</li> <li>8. Fill</li> </ol> Call GXi Parts & Service (919)-550-3221
Engine runs erratic	<ol style="list-style-type: none"> <li>1. Spark plug wire loose.</li> <li>2. Unit running on CHOKE. (If equipped)</li> <li>3. Blocked fuel line or stale fuel.</li> <li>4. Water or dirt in fuel system.</li> <li>5. Dirty air cleaner.</li> <li>6. Carburetor out of adjustment.</li> </ol>	<ol style="list-style-type: none"> <li>1. Connect and tighten spark plug wire.</li> <li>2. Move choke lever to OFF position.</li> <li>3. Clean fuel line; fill tank with clean, fresh gasoline.</li> <li>4. Drain fuel tank. Refill with fresh fuel.</li> <li>5. Clean or replace air cleaner.</li> <li>6. Call GXi Parts &amp; Service (919)-550-3221</li> </ol>
Too much vibration	<ol style="list-style-type: none"> <li>1. Loose parts or clogged carousel .</li> <li>2. Trying to force branches or logs too fast into the side chute</li> <li>3. Trying to force branches in the funnel or attempting to put branches into funnel while side chute is in use</li> </ol>	<ol style="list-style-type: none"> <li>1. Call GXi Parts &amp; Service (919)-550-3221</li> <li>2. Cut off excess limbs off of large branches and ensure blades are sharp</li> <li>3. Allow the branches to feed through the side chute first before attempting to use the funnel. Also do not put branches in the funnel.</li> </ol>
Engine overheats	<ol style="list-style-type: none"> <li>1. Engine oil level low.</li> <li>2. Dirty air cleaner.</li> <li>3. Carburetor not adjusted properly.</li> </ol>	<ol style="list-style-type: none"> <li>1. Fill crankcase with proper oil.</li> <li>2. Clean or replace air cleaner.</li> <li>3. Call GXi Parts &amp; Service (919)-550-3221</li> </ol>
Occasional skip (hesitates)	<ol style="list-style-type: none"> <li>1. Spark plug gap too close.</li> </ol>	<ol style="list-style-type: none"> <li>1. Adjust gap to .030".</li> </ol> Call GXi Parts & Service (919)-550-3221

**NOTE:** For repairs beyond the minor adjustments listed above, contact GXi Parts and Service (919)-550-3221 for support over the phone or getting setup with your nearest authorized service dealer.



<b>Problem</b>	<b>Cause</b>	<b>Remedy</b>
Unit does not discharge	<ol style="list-style-type: none"><li>1. Discharge chute clogged.</li><li>2. Foreign object lodged in carousel.</li><li>3. Low engine RPM.</li></ol>	<ol style="list-style-type: none"><li>1. Stop engine immediately and disconnect spark plug wire. Clean flail screen and inside of discharge opening.</li><li>2. Stop engine and disconnect spark plug wire. Remove lodged object.</li><li>3. Always run engine at full throttle. Call GXi Parts &amp; Service (919)-550-3259</li></ol>
Rate of discharge slows	<ol style="list-style-type: none"><li>1. Low engine RPM.</li><li>2. Chipper blades are dull.</li></ol>	<ol style="list-style-type: none"><li>1. Always run engine at full throttle</li><li>2. Replace chipper blades or see your authorized service dealer. Call GXi Parts &amp; Service (919)-550-3221</li></ol>

**NOTE:** For repairs beyond the minor adjustments listed above, contact GXi Parts and Service (919)-550-3221 for support over the phone or getting setup with your nearest authorized service dealer.





# Limited Warranty & Service

Products Covered by this Warranty	Length of Warranty: *(from the date of original retail purchase)		
	Noncommercial /Nonrental	Commercial	Rental
Engine	12 months	3 months	3 months

\*Length of Warranty: Consumable parts such as oil, spark plugs, filters, blades, and belts are not covered by this warranty. Warranty repairs will be made without charge for parts and labor for the first 6 months. After the first 6 months, the limited warranty covers the costs of replacement parts only.

**To Qualify for this Warranty:**

The product must be purchased in the United States from a dealer authorized by GXi Outdoor Power, LLC to sell the product. This warranty applies to first retail purchaser/owner during the applicable warranty time period. No warranty registration is necessary to obtain warranty on BRUSH MASTER products. Save your proof of purchase receipt.

**To Obtain Warranty Service:**

You must take the BRUSH MASTER Power Equipment product, accessory, replacement part, apparel or the power equipment on which the accessory or replacement part is installed, and proof of purchase, at your expense, to any BRUSH MASTER Power Equipment service location in the United States and Canada, who is authorized to service that product, during the service location's normal business hours. If you are unable to obtain warranty service, or are dissatisfied with the warranty service you receive, take the following steps: First, contact the manager of the service center involved; normally this will resolve the problem. However, if you should require further assistance, write or call the GXi Customer Service.

**What GXi Outdoor Power Will Repair or Replace under Warranty:**

GXi will repair or replace, at its option, any part that is proven to be defective in material or workmanship under normal use during the applicable warranty time period subject to the exclusions stated herein. GXi has the right to recover warranty administration costs from the owner if the root cause of the malfunction is found to be other than defective material or workmanship. This warranty is void if the owner fails to follow the prescribed operating, maintenance and storage procedures described in this manual. This specifically refers to ensuring routine oil changes are made, that fuel stabilizer is used for long-term storage and that the chipper/shredder is used in accordance with the operating instructions.

Anything replaced under warranty becomes the property of GXi. Parts replaced under warranty will be considered as part of the original product and any warranty on those parts will expire coincident with the original product warranty.

The customer is responsible for transportation to and from a service center

**Exclusions:**

This warranty does not cover: normal wear, contaminants in the fuel or oil; damage as a result of use in an application for which the product was not designed; damage caused by incorporation or use of unsuitable attachments or parts, unauthorized alteration, or other misuse and neglect; damage caused by failure to follow the prescribed warnings, operating practices, proper maintenance and storage procedures; parts affected or damaged by accident and/or collision; damage due to shipping, handling, storage or any causes other than defects in material or workmanship of the product. Pickup and delivery service is dependent upon each service center and at the customers expense.

**Disclaimer of Consequential Damage and Limitation of Implied Warranties:**

GXi disclaims any responsibility for loss of time or use of the product, transportation, commercial loss, or any other incidental or consequential damage. Any implied warranties are limited to the duration of this written limited warranty.

**THIS WARRANTY IS VOID IF THE MANUFACTURING DATE AND THE SERIAL NUMBER ON THE EQUIPMENT HAS BEEN REMOVED OR THE EQUIPMENT HAS BEEN MODIFIED.**

**EMISSION CONTROL SYSTEM INFORMATION**

The U.S. and California Clean Air Acts

EPA and California regulations require all manufacturers to furnish written instructions describing the operation and maintenance of emission control systems. The following instructions and procedures must be followed in order to keep the emissions from your BRUSH MASTER engine within the emission standards. Maintenance, replacement, or repair of the emission control devices and systems may be performed by any engine repair establishment or individual, using parts that are "certified" to EPA standards.

The emission control systems on your BRUSH MASTER engine were designed, built, and certified to conform with EPA regulations. We recommend the use of genuine BRUSH MASTER parts whenever you have maintenance done. These original-design replacement parts are manufactured to the same standards as the original parts, so you can be confident of their performance. The use of replacement parts that are not of the original design and quality may impair the effectiveness of your emission control system. A manufacturer of an aftermarket part assumes the responsibility that the part will not adversely affect emission performance. The manufacturer or re-builder of the part must certify that use of the part will not result in a failure of the engine to comply with emission regulations.

Emission controls are covered by this warranty for all uses for a period of 3 years from original retail purchase date, this coverage extends to subsequent owners of the product with proof of original purchase.

For emissions warranty service call 1-800-393-0668 or e-mail customerservice@gxioutdoorpower.com .